

Letter Section

A redesigned kasten core barrel and sampling technique

Eberhard Zanger and I.N. McCave

Department of Earth Sciences, University of Cambridge, Downing Street, Cambridge CB2 3EQ (U.K.)

(Received February 5, 1990; accepted March 13, 1990)

ABSTRACT

Zanger, E. and McCave, I.N., 1990. A redesigned kasten core barrel and and sampling technique. *Mar. Geol.*, 94: 165–171.

A modified kasten core barrel was developed to obtain cores with nearly 100% sediment retrieval while minimizing disturbance of the sediment/water interface. One side of the 15×15 cm square barrel is doubled by a second movable plate which can be moved upwards by a series of hand screws thus enabling complete sideways extrusion of the core. This produces a set of subcores or slabs of equal quality with preserved stratigraphy which can be X-rayed, subsampled, stored or frozen for geochemical studies. The new kasten core barrel is effective in rough weather, inexpensive to build, easy to handle and enables fast core processing on board.

Introduction

Our current studies of the Late Quaternary carbon fluxes in the northeastern Atlantic Ocean require high-quality samples of the uppermost few metres of the seabed, which cannot be provided by any of the standard coring methods. Large-diameter box corers (Reineck, 1963; Bouma and Marshall, 1964; Rosfelder and Marshall, 1967; Bouma, 1969) are too shallow to penetrate most pre-Holocene deposits. On the other hand, cores obtained from kastenlot corers (Kögler, 1963; Kuehl et al., 1985) (generally termed “kasten corers”) are difficult to subsample and do not provide undisturbed subcores. A combination of kasten and box core designed by Johnson (1988) was disregarded for our purposes, because of the costly construction of the barrel and the difficulty of handling its great weight when full.

Thus, it was decided to develop a new corer and sampling technique which would meet the following requirements:

- (1) Minimal disturbance of the sediment surface.
 - (2) Sufficient length to cover the Holocene and Late Pleistocene.
 - (3) Provision of undisturbed subcores of equal quality with preserved stratigraphy.
 - (4) Provision of sufficient material for several different research groups, including a reference section for long-term storage.
 - (5) Possibility of large full-size X-rays and photographs.
 - (6) Retention of porewater in situ to allow geochemical studies.
 - (7) Ease of handling the full barrel on deck in a moderate sea.
 - (8) Quick (< 5 h) core processing on board.
- Furthermore, the subsampling method was expected to be inexpensive and permit easy handling of core sections on board and on land.

Corer design

The new design rests largely on the “kastenlot” technique initially provided by Kögler



Fig. 1. The full 3 m long kasten core returning from the seabed. At the top of the corer is a 750 kg weight which is connected to the barrel by the core head. At the bottom of the barrel is the sliding weight and the core catcher.

(1963) and improved by Kuehl et al. (1985). A kasten core set up (Fig. 1) typically includes four parts: (1) a core catcher with a shutter-like closure, (2) a square core barrel and (3) a core-head which links the square barrel to a

circular weight stand (4). The shutter-like closure consists of two doors which are held under tension in a retracted position and flanking the inside wall of the core catcher. The doors are connected to levers positioned on the out-

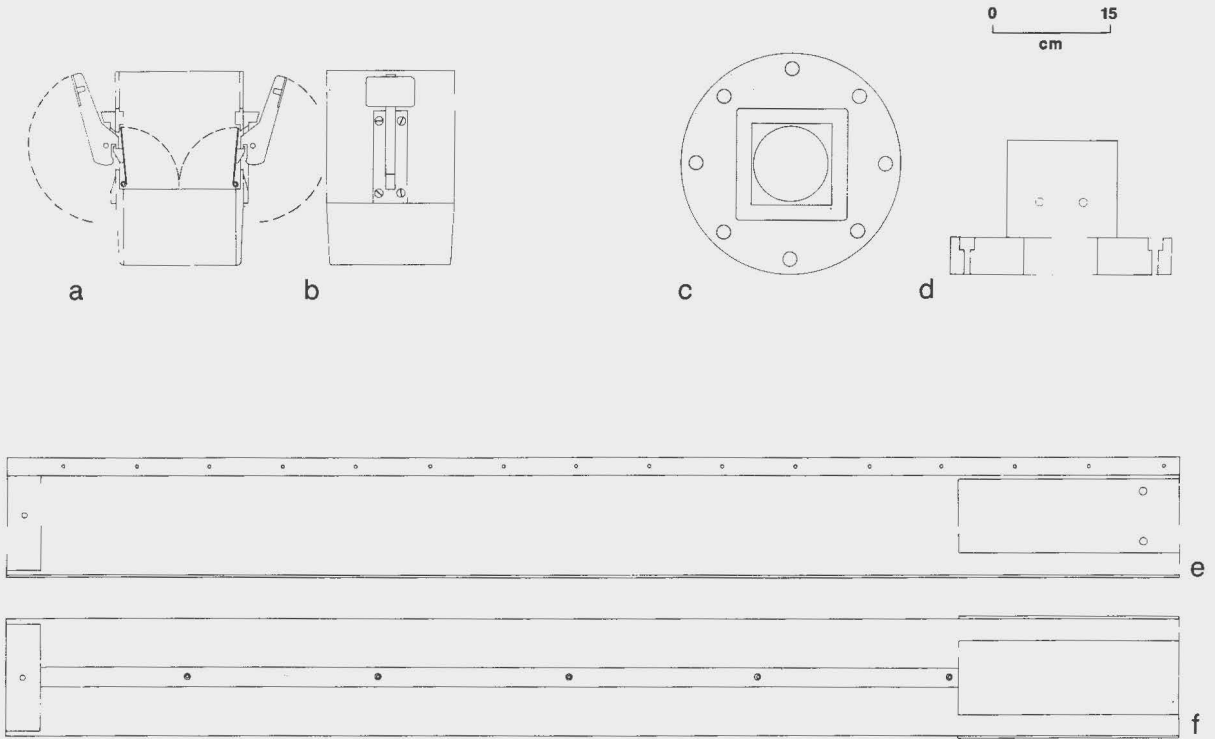

Fig. 2. Schematic drawings of core catcher (a and b), core head (c and d) and 2 m core barrel (e and f). The core barrel is reinforced at the top and bottom and on its basal side. In (e) and (f), the top is to the right.

side. When the core barrel is lifted from the seabed, the outer levers are forced downwards by the drag of the surrounding sediment. This releases the tension on the doors which spring forward into a closed position, thus entrapping the sediment. For our purposes a slightly improved core catcher was made of stainless steel using the standard dimensions of corers previously built by the IOS (Institute of Oceanographic Sciences, Wormley) and of the RVS (Research Vessel Service, Barry) corers (Figs. 2a and b). The RVS also provided a standard core head (Figs. 2c and d). A circular 10 cm diameter hole through the core head allows the escape of water during penetration. A simple ball valve on the top of the weight shuts the central hole during the corer's ascent, thus preventing the core from being washed out. When the new corer was tested during *Discovery* cruise 184, a weight of 750 kg was used.

The core barrel itself (Figs. 2e and f) was

built using the basic design and dimensions provided by Kuehl et al. (1985), who had recognized the advantages of a U-shape barrel over the original L-shaped halves for sampling soft muds. The U-shaped stainless steel boxes with square cross sections (15×15 cm) and matching lids were made from 2.5 mm thick T-316 steel. One 3 m long barrel was provided for soft muds and one 2 m long barrel for more consolidated deposits. Steel plates (4 mm thick) at the top and bottom ends of the corers reinforce the links between core barrel, head and catcher. One side of the barrel forms the lid which is attached to the corer body by 4 mm countersunk sheet metal screws (6 mm long) 10 cm apart. Installing and removing these screws is aided by two rechargeable electric screwdrivers and takes approximately 2 minutes. The core catcher is attached to the barrel by four 9 mm hexagonal-headed bolts (12 mm long), whose threads are cut into the core bar-



Fig. 3. The U-shaped core barrel is placed horizontally in two carpenter's vices which are attached to a work bench. The upper side of the barrel which serves as the lid has been removed. The sediment surface is protected by a square plate which prevents it from slumping. By turning the threaded T-bars on the underside of the barrel, the double bottom is forced upwards and extrudes the sediment. In this photograph, half of the core has been removed and a series of plastic trays has been pressed into the core. Clearly visible are the reinforcement plates where the barrel is connected to the core head.

rel and reinforcement plates. The core head is connected to the barrel by two 20 cm long bolts which are secured by locknuts on the opposite side.

Almagor and Argas (1981) first introduced a sliding weight of 30 kg to stabilize the corer in a vertical position during descent; this principle was later successfully repeated by Kuehl et al. (1985). Such a weight was also used in the design presented here, although the wires which initially connected the weight to the core head were removed early on because they became tangled up between the barrel and the sliding weight. Instead, two L-shaped stopper

plates were installed on either side of the core catcher to limit the passage of the weight.

The invention of a double bottom to raise the sediment above the lip of the U-shaped trough during subsampling represents the most obvious departure from previous kasten corers. The double bottom comprises a 2 mm steel sheet in the base of the U-shaped trough which is attached to the corer body externally by 6 mm countersunk crosshead screws (10 mm long). The threads in the steel sheet are 6 mm in diameter, and the barrel itself holds 8 mm threads. Extrusion is affected by removing the 6 mm screws and replacing them by 8 mm

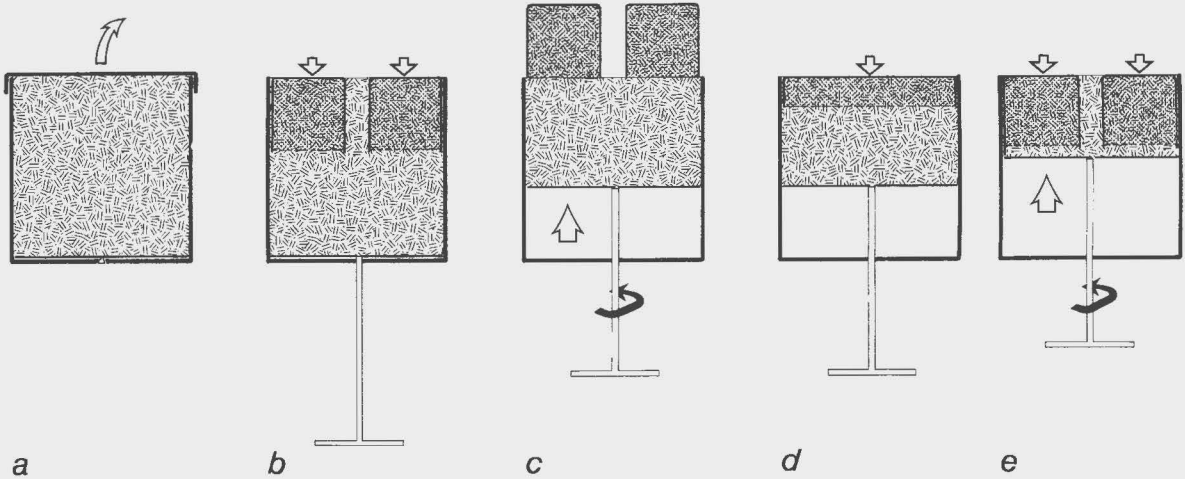

Fig. 4. Schematic diagram of the sampling technique in cross section. a. Core barrel with lid, which during subsampling is held in two carpenter's vices. b. Two U-shaped PVC drainpipes are pressed into the surface of the core; the bolts which hold the double bottom are removed and replaced by threaded T-bars. c. By turning the T-bars the core is extruded upwards, thus exposing the drainpipes. These are then separated from the remaining core with a cheesewire. d. The new surface is levelled for photography and core description. Custom-made 15 cm wide plastic trays are then pressed into the core to provide X-ray slabs. e. The double bottom is lifted by 2.5 cm in order to withdraw the X-ray slabs and two more drainpipes are then pressed into the core.

threaded T-bars (180 mm long) which gradually force the steel sheet up, thereby extruding the sediment (Figs. 3 and 4).

Sampling technique

After raising the corer to deck level but before the corer is inclined from the vertical the sediment surface must be stabilized to prevent slumping. To accomplish this a perforated steel plate or alternatively a piece of 2 mm mesh sieve is installed inside the core barrel prior to coring. Before the corer is brought aboard, this plate is pushed down onto the sediment surface by a 3 m long wooden pole which is inserted through the central hole of the core head. Having secured the sediment surface the corer is then brought onto the ship, laid horizontal, the weight is removed, the barrel is uncoupled from the core head and the core is man-handled into the laboratory (the total weight being < 140 kg).

In the laboratory, the barrel is secured horizontally in a series of carpenter's vices to main-

tain access to the underside of the barrel (Fig. 3). Once the lid has been removed, two $6.0 \times 6.0 \times 100$ cm pieces of PVC drainpipe with one side cut off are pressed into the core's surface parallel to each other (Fig. 4b). Two or three small holes in the drainpipes allow the air to escape during this process. Individual water content samples (ca. 10 cm^3) collected at appropriate intervals are taken from the strip of sediment which remains exposed between the drainpipes. The bolts which secured the double bottom sheet are then replaced by 18 cm long T-bars which force the bottom sheet upwards until the drainpipes become fully exposed (Fig. 4c). They are then separated from the core with a cheesewire and closed using their fourth side as a lid.

When the drainpipes are removed the central part of the core becomes exposed, enabling photography and core description. Following this, a layer of $15.0 \times 33.0 \times 2.5$ cm polypropylene trays is pressed upside down into the sediment (Fig. 4d). Afterwards, the double bottom is lifted again by 2.5 cm to allow removal

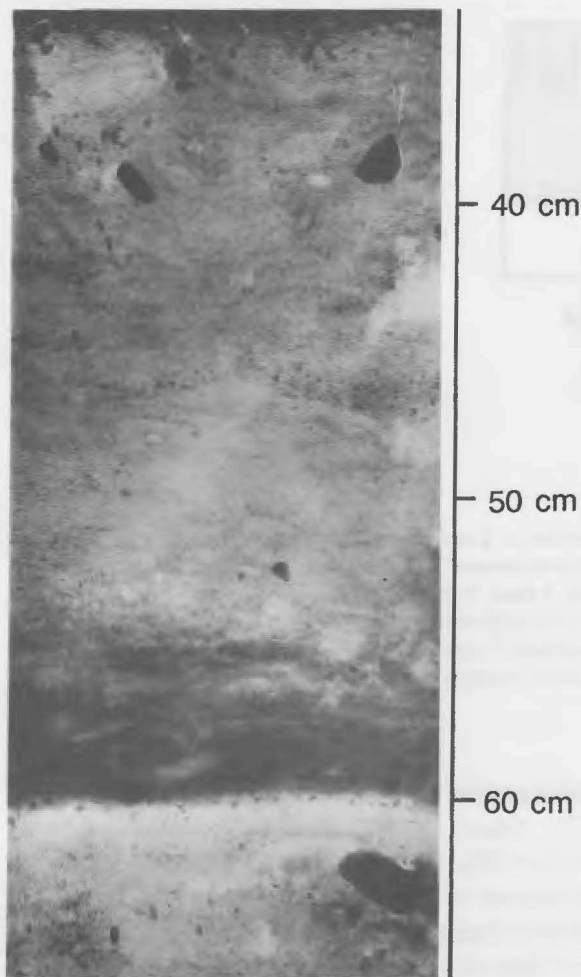

Fig. 5. X-ray of core 6 (33–67 cm) showing hemipelagic mud with iron-rich bands and terrigenous dropstones.

of the trays which are then sealed in clear plastic. Finally, a second layer of square drainpipe is taken from the core (Fig. 4e). Alternatively, two more layers of slabs may be taken.

Results and discussion

The new kasten core barrel was used seventeen times during *Discovery* cruise 184. In only two instances did the barrel return empty or bearing just a few pebbles; at both of these places photographs of the seabed and a 3.5 kHz survey indicated a coarse residual surface. The maximum possible core length of the 3 m bar-

rel turned out to be 2.64 m, because core head and core catcher take up some of the barrel length. The 2 m barrel was rarely used, because its longer counterpart was sufficiently rigid to withstand bouncing on hardground. Depending on the facilities for core handling on board one could consider building a 4 m barrel. The average core length during fourteen successful attempts was 2.1 m. The corer had repenetrated in two cases due to the rolling of the ship in rough sea (Weaver and Schultheiss, 1983). The cores were taken from a depth of between 1150 and 4545 m. Most of the cored sediment consisted of mud; some, however, contained pebbles up to 6 cm in diameter.

During the cruise, full-scale X-ray photographs of each core were produced using the 2.5 cm thick slabs in the polypropylene trays (Fig. 5). Fine laminae in a turbidite showed no indication of reflection near the barrel wall. The X-ray slabs are also well suited for magnetic susceptibility measurements, because the stratigraphy is kept undisturbed but removed from the metal core barrel. The magnetic susceptibility of the sediment layers was determined at 2 cm intervals using a portable Bartington MS2 instrument. An X-ray of core 6 (33–67 cm, Fig. 5) shows hemipelagic mud with a diagenetically indurated layer which coincides perfectly with peaks in magnetic susceptibility and water content (Fig. 6), although this information was nevertheless collected from different subcores.

Acknowledgements

This development was made as part of the Biogeochemical Ocean Flux Study (BOFS), a component of the Joint Global Ocean Flux Study and funded by the U.K. Natural Environment Research Council under grant GST 02426. We are grateful to Peter Smith and his workshop team for overseeing the construction of the corer and to Ken Harvey for his photographic work at sea and on land. The technicians on *Discovery* cruise 184, Keith

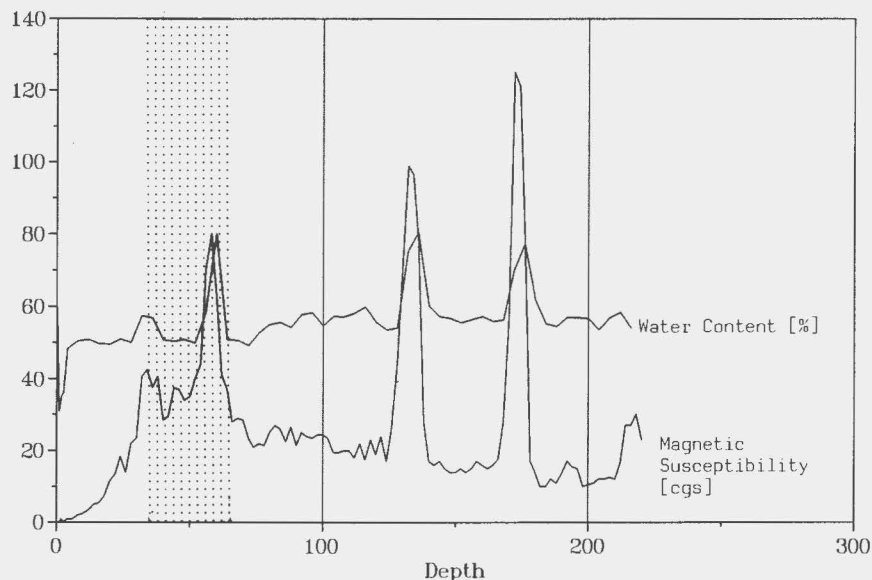

Fig. 6. Water content and magnetic susceptibility fluctuations in core 6. The stippled area marks the section in Fig. 5.

Goy, Bob Wallace, Michael Davis, Bernie Woodley and Darryl Phillips operated and maintained the corer with an exceptional degree of dedication. Bob Wallace of IOS also kindly provided the drawings of the core catcher. John Atherton provided helpful support during the development of this technique. This letter represents Cambridge Earth Science Contribution 1672.

References

- Almagor, G. and Argas, D., 1981. Long hydroplastic (plastic-barrel) sediment cores suitable for geotechnical testing. *Mar. Geol.*, 43: M69-M73.
- Bouma, A.H., 1969. *Methods for Study of Sedimentary Structures*. Wiley, New York, pp. 332-342.
- Bouma, A.H. and Marshall, N.F., 1964. A method of obtaining and analyzing undisturbed ocean sediment samples. *Mar. Geol.*, 2: 81-99.
- Johnson, R.F., 1988. A box corer 30 cm square and 4 m long. *Cont. Shelf Res.*, 8: 1011-1024.
- Kögler, F.C., 1963. *Das Kastenlot*. *Meyniana*, 13: 1-7.
- Kuehl, S.A., Nittrouer, C.A., DeMaster, D.J. and Curtin, T.B., 1985. A long, square-barrel gravity corer for sedimentological and geochemical investigation of fine-grained sediments. *Mar. Geol.*, 62: 365-370.
- Reineck, H.E., 1963. *Der Kastengreifer*. *Natur und Mus.*, 93: 102-108.
- Rosfelder, A.M. and Marshall, N.F., 1967. Obtaining large, undisturbed, and oriented samples in deep water. In: A.F. Richards (Editor), *Marine Geotechnique*. Univ. Illinois Press, Urbana, pp. 243-263.
- Weaver, P.P.E. and Schultheiss, P.J., 1983. Detection of repenetration and sediment disturbance in open-barrel gravity cores. *J. Sediment. Petrol.*, 53 (2): 649-678.
- Werner, F., 1973. An improved core catcher for the Kiel box corer ("Kastenlot"). *Mar. Geol.*, 15: M59-M66.